

BeneHeart R3

Electrocardiograph

Physical

Height:	56 mm
Width:	260 mm
Depth:	194 mm
Weight:	1.2 Kg including battery, internal AC power supply

Processing

ECG analysis sampling rate:	500 samples/ second (sps)
Digital sampling rate:	1000 samples/ second/ channel
Pacer detection sampling rate:	16,000 samples/second/channel
ECG amplifier:	DC-coupled
Acquisition mode:	Pre-acquisition or post-acquisition, provide 10 seconds of instantaneous ECG acquisition
Dynamic range:	AC Differential ± 10 mV, DC offset ± 600 mV
Resolution:	1 μ V/LSB @ 500 sps
Frequency response:	-3 dB @ 0.05 Hz to 150 Hz
Baseline drift filter:	0.05 Hz, Baseline Drift Removal(BDR)
High cut-off frequency:	20 Hz, 35 Hz, 150 Hz
AC filter:	50/60 Hz ± 0.3 Hz
Common mode rejection:	≥ 110 dB (with AC filter switched off)
ADC:	24 bit
Input impedance:	≥ 50 M Ω @ 10 Hz, defibrillator protected
Patient leakage:	<10 μ A
Heart rate meter:	30 to 300 BPM $\pm 10\%$ or ± 5 BPM, whichever is greater
Startup time:	≤ 5 second
Sensitivity/gain:	5, 10, 20 mm/mV, Auto

Display

Color:	24 bit Color display
Display type:	5 inch diagonal, 16: 9 aspect ratio, TFT LCD with LED graphics backlit
Display resolution:	800 * 480
Display data:	Patient ID, gender, age, heart rate, clock, battery power indicator, waveforms, lead labels, speed, gain, filter settings, warning messages, information messages, network status and USB

Power

Power supply:	AC input (without external power adaptor) or battery operation
---------------	--

AC Power

Input voltage:	100 to 240 VAC $\pm 10\%$
Input power:	60 VA
AC frequency:	50/60 Hz ± 3 Hz

Battery

Battery type:	rechargeable Lithium ion battery
Battery capacity:	11.1 V typical, 2500 mAh 6 hours of continuous operation without recording or 500 ECGs in 2.5 x 4 format at 25 mm/s and 10 mm/mV
Battery charge time:	3.5 hours with power off



Writer

Writer technology:	Thermal dot array
Writer Width:	80 mm
Writer speed:	5, 12.5, 25, 50 mm/s
Number of traces:	3 leads + 1 rhythm or 3 leads; user selectable
Writer speed accuracy:	$\pm 5\%$
Writer amplitude accuracy:	$\pm 5\%$
Writer resolution:	Horizontal 32 dots/mm @ 25 mm/s, Vertical 8 dots/mm
Paper type:	Thermal roll paper (20 m) & Z- fold paper (80 mm width, 200 sheets/pack)

Software

Measurement and interpretation:	Supports measurement and interpretation with the University of Glasgow ECG analysis algorithm
Resting ECG mode:	Records and prints 12-lead resting ECG with 10-second duration as a standard feature
Supported patient information:	Patient ID, secondary ID, age, date of birth, gender, race, medication, class and V3 electrode Placement
Internal storage:	800 ECGs in internal memory
ECG Storage format:	PDF format and Mindray storage format
Multi-language support:	Supports 13 languages

Report Formats

Thermal printer report formats:	4 by 2.5 s (Sequential)
	4 by 2.5 s Compact
	4 by 2.5 s + 1 rhythm lead
	4 by 2.5/5/7.5/10 s (Simultaneous)
	Autorhythm (60 second ECG data for 1 rhythm lead)
	Continuous 1 or 3 channel manual rhythm
PDF report format:	4 by 2.5 s + 1 rhythm lead
(A4/letter format)	2 by 5 s
	2 by 5 s + 1 rhythm lead
	1 by 10 s

Accessories

ECG patient cable with banana plugs, Limb Clamps, Chest Bulbs (IEC/AHA)
ECG cable with Electrode clips (IEC/AHA)
Country-specific power cords
Z-fold and Roll paper

Environmental Specification

Temperature	
Operating:	0 °C to 40 °C
Transport/storage:	-20 °C to 60 °C
Humidity	
Operating:	15% to 95% RH non-condensing
Transport/storage:	10% to 95% RH non-condensing
Pressure	
Operating:	57.0 kPa to 107.4 kPa
Transport/storage:	16.0 kPa to 107.4 kPa



BeneHeart R3

Electrocardiograph

Your Faithful Consultant for Resting ECG Diagnosis

Mindray Building, Keji 12th Road South,
High-tech Industrial Park, Nanshan, Shenzhen 518057, P.R. China
Tel: +86 755 8188 8998 Fax: +86 755 26582680
E-mail: intl-market@mindray.com www.mindray.com
Mindray is listed on the NYSE under the symbol "MR"

mindray is a trademark of Shenzhen Mindray Bio-Medical Electronics Co., Ltd.
©2013 Shenzhen Mindray Bio-Medical Electronics Co., Ltd. All rights reserved. Specifications subject to changes without prior notice.
P/N:ENG-BeneHeart R3-210285x4P-20130523



mindray
healthcare within reach

BeneHeart R3

Electrocardiograph

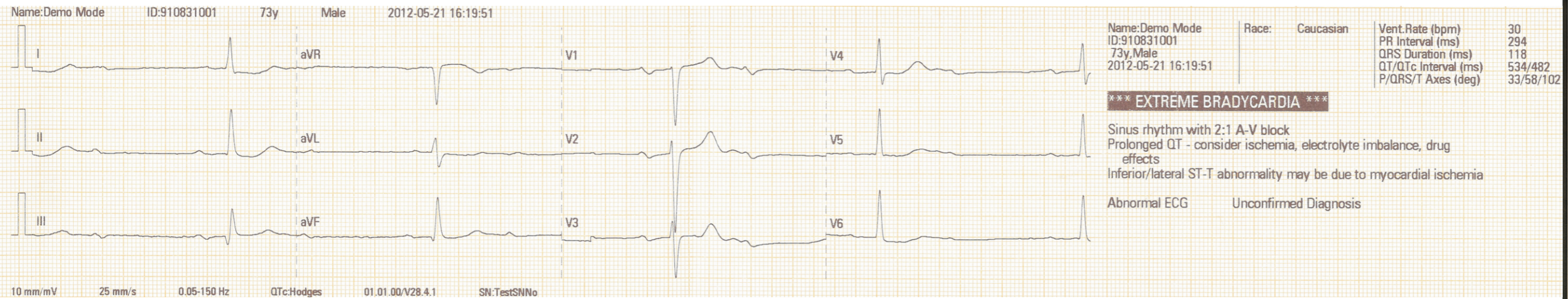

The Glasgow algorithm is the first to be based on specific variables, including age, gender, race, medication, and class in order to maximize the accuracy of the ECG interpretation.

On the report, a headline may highlight one of several “critical value warnings” to alert medical attendants of findings that need immediate attention.

For neonates and children, lead V4R is used instead of V3 to improve the diagnostic accuracy.

Reliable Analysis

BeneHeart R3 utilizes the University of Glasgow ECG analysis algorithm, one of the world-leading resting ECG interpretations with 50 years of history.

Clear Display

5-inch color screen offers the highest resolution in industry, enabling clinicians to observe real-time waveforms accurately.

Great Portability

The BeneHeart R3 weighs only 1.2kg with battery, easy to carry .

Convenient Operation

ECG recording is automatically unfolded on the writing pad on top of the machine for notes or signature.

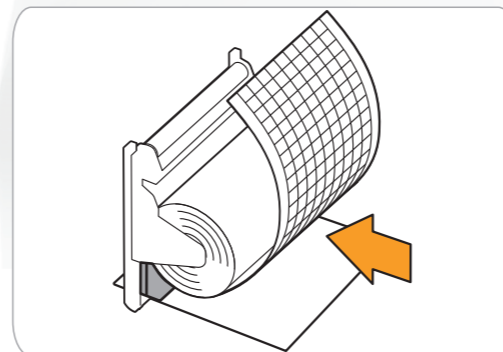
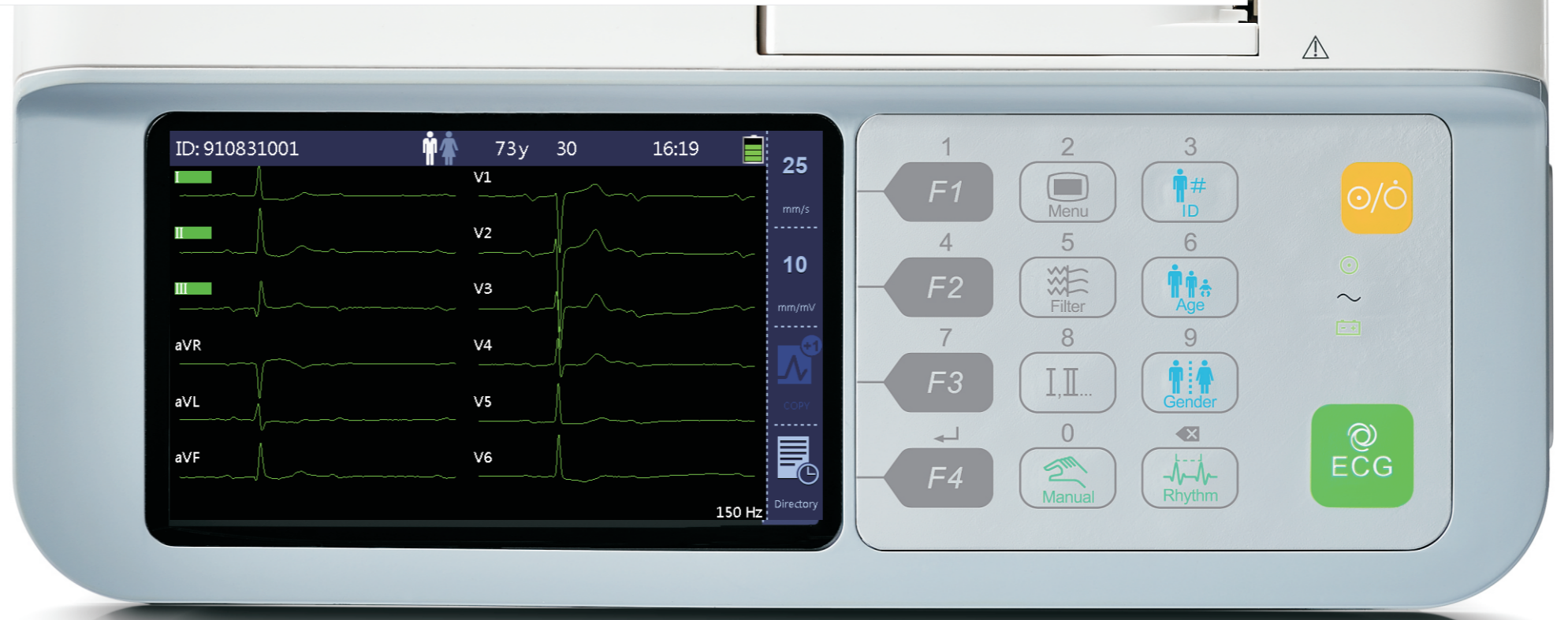

With rolling paper

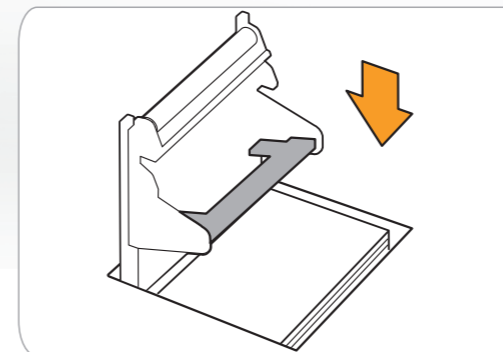

With Z-fold paper

Unique Recorder

Compatible with both rolling paper and Z-fold paper, you can easily switch between these two styles of papers without dismantling the pressure lever.